

# From the Smart Hands to Tele-Operations

**Imre J. Rudas, József Gáti, Anikó Szakál, Krisztina Némethy**

Óbuda University, Bécsi út 96/b, H-1034 Budapest, Hungary

{rudas,gati,szakal}@uni-obuda.hu, nemethy.krisztina@rh.uni-obuda.hu

---

*Abstract: Professor Dr. Antal K. Bejczy, the Hungarian-born scientist innovator worked for the NASA Jet Propulsion Laboratory (JPL) in California from 1969, where he developed, with his colleagues, the first dynamic model of robotic manipulators based on the Lagrangian formulation. In the field of teleoperation, he developed, and sponsored through NASA Telerobotics program, a number of prototypes aimed at achieving full Telepresence in space and undersea. He pioneered robot dynamics development and published one of the first papers in this field, describing “smart hands” with multi-fingered, effector equipped sensors. One of his research papers named “The Robot Arm Dynamics and Control” was published by JPL in 1974. This was one of the most important papers in the history of robotics.*

*Keywords: Antal K. Bejczy; smart hands; exoskeleton; Antal Bejczy Center for Intelligent Robotics; dynamic model of robotic manipulators; teleoperation*

---

## 1 Prof. Dr. Antal K. Bejczy at NASA JPL

Antal K. Bejczy was born in Hungary in 1930. After high school graduation with “excellence” in Kalocsa at Jesuits, he was working for an electrical motor factory



for some years. Due to political reasons he could only start his studies in 1953, at the Technical University of Budapest, in the field of electrical engineering. He left Hungary with one of his friends after the revolution in 1956. He went to Norway, where he completed his University studies, in the field of applied physics, at the University of Oslo in Norway in 1963. His thesis work concerned the geometric problems of atomic reactors. After that, he taught statistical thermodynamics at the University, until 1966. He met in Norway, the world famous Hungarian born

scientists Tódor Kármán, who invited him to the JPL NASA Laboratory in the USA. (The NASA Jet Propulsion Laboratory was established by Tódor Kármán). Because of his meeting Tódor Kármán, Bejczy became interested in the new field of study. He applied at four American Universities and he received a NATO/Fulbright scholarship from the California Institute of Technology (Caltech) in Pasadena, as a Senior Research Fellow in 1966.

## RESEARCH FELLOWS

Nadine Alleaume,* D.Sc. ....	<i>Applied Science</i>
Johann Arbocz, Ph.D. ....	<i>Aeronautics</i>
Antal K. Bejczy, Cand. Real. ....	<i>Engineering</i>
Halka Bilinski,* Ph.D. ....	<i>Environmental Health Engineering</i>
George W. Bluman,* Ph.D. ....	<i>Applied Mathematics</i>

Figure 1

Information for students: California Institute of Technology 1968

He worked on optimal control and nonlinear filtering problems. He joined the Jet Propulsion Laboratory (JPL) as a Member of the Technical Staff in 1969. He became a Senior Research Scientist (a professor rank at JPL-Caltech) in 1985 and the Technical Manager of the robotics program at JPL.



Figure 2

The Advanced Teleoperation Group with Antal K. Bejczy at JPL in 1986

He was also an Affiliate (non-resident) Professor in System Science and Mathematics at Washington University in St. Louis, MO, from 1983, with the duty of establishing and maintaining the Graduate Studies in Robotics. There he supervised – together with local professors – eleven successful Ph.D. students in their thesis work, in the field of robotics. He served as a member and chair of various governmental or private technical committees for creating and evaluating robotic and automation proposals or establishing state-of-the-art in robotics and automation.

He was the successful Principal Investigator of the robot arm, force-moment sensor, flight experiment for the Space Shuttle in 1994.

## 1.1 Publications of Antal K Bejczy

He initiated work on modeling and sensing based intelligence, in robot control, published more than 160 technical papers, 11 book chapters on topic sensing, dynamic modeling, control, Telepresence, virtual environments, human-machine interaction in robotics and on the application of robots in space research.

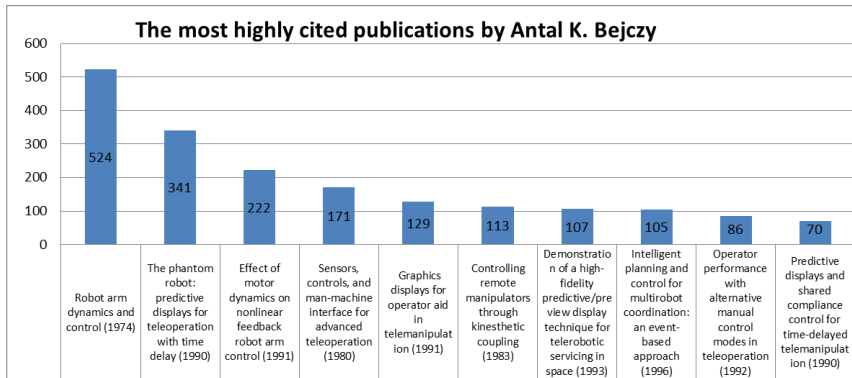

Figure 3

Most highly cited publications, Source: Google Scholar 2015

The book titled Robot Arm Dynamics and Control (Figure 3) by Antal K. Bejczy (1974) is the sixth highest accessed publication according to the Google Scholar in the field of Robot Arm Research. The two main topics of his book relate to the dynamic aspects and central problems of the 6 degrees of freedom, JPL Robot Research Project manipulator:

- Variations in total inertia and gravity loads as the joint outputs
- The relative importance of gravity and acceleration-generated reaction torques of forces versus inertia torques of forces. Bejczy [1]

The core idea of the control is that the inputs should be computed from the state. The main result is the construction of a set of greatly simplified state equations which describe total inertia and gravity load variations at the output of the six joints with an average error of less than five percent. The dynamic model of the six degrees of freedom JPL Robot Research Project manipulator can be obtained from the known laws of the Newtonian mechanics and physical measurements. The algorithm is based on a special representation of link coordinate frames in jointed mechanism and formalism of the Lagrangian mechanics. The dynamic model is described by a set of six coupled nonlinear differential equations which contains a large amount of torque or force terms classified into four groups. The above general algorithm (Figure4) describe: the manipulator equations of motion is given by following expression for the torque of force  $F_i$  acting at joint “i” Lewis at all [11]

$$\sum_{j=1}^n \left\{ \sum_{k=1}^j \left[ \text{Trace}(U_{jk} J_j U_{ji}^T) \dot{q}_k \right] + \sum_{k=1}^j \sum_{p=1}^j \left[ \text{Trace}(U_{jkp} J_j U_{ji}^T) \dot{q}_k \dot{q}_p \right] - m_j G U_{ji} \bar{p}_j \right\} = F_i, \quad i = 1, 2, \dots, n \quad (1)$$

where superscript **T** denotes the transpose of the matrix  $U_{ji}$ , and

Figure 4

Lewis, R.A., Bejczy A. K., RRP Manipulator Conventions, Coordinate Systems, and Trajectory Consideration. 1972

He co-edited a book on Parallel Computation Systems in Robotics [5]. He was also on the editorial board of four robotics and automation journals like the International Journal of Robotics and Automation.

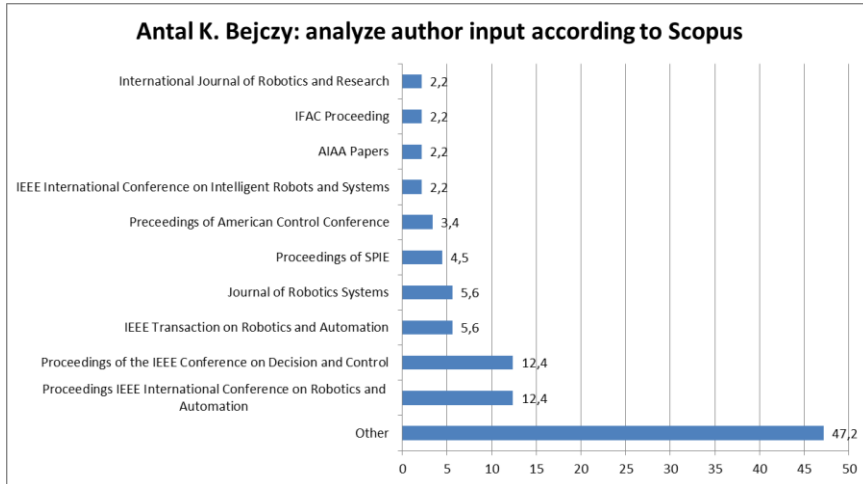

Figure 5

Author input: Source: Scopus 2015

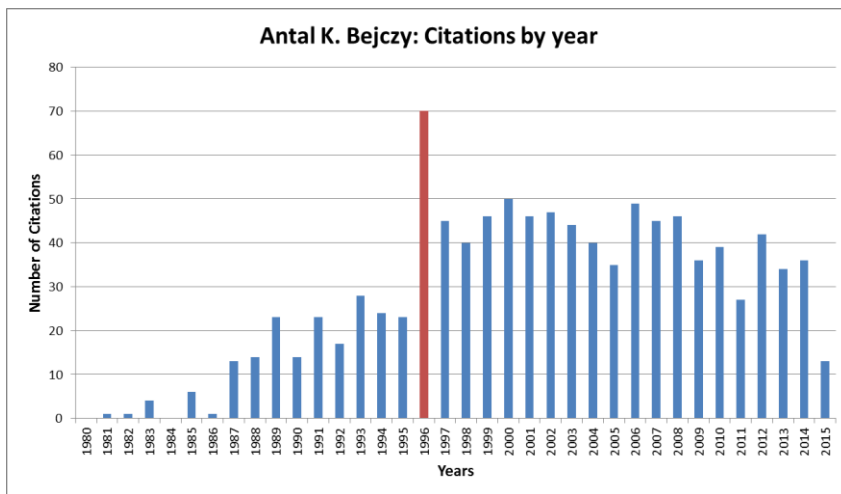

Figure 6

Citations by year, Source: Scopus 2015

When the Mars Pathfinder spacecraft inaugurated a return to the Red Planet in 1996, the citations of Antal K. Bejczy's papers were significantly higher level like before.

## 1.2 Pathfinder

*“JPL initiated the Pathfinder project, a shuttle-based acquisition and tracking experiment, for the Strategic Defense Initiative Organization. The project's two major goals are to demonstrate technologies associated with tracking a missile-booster plume and acquiring data on the plume from which its signature and relationship to the booster can be derived. Progress was made in designing the mission, conducting the preliminary design, and starting to build test and protoflight hardware. The Pathfinder project was to fly as part of a shuttle mission in late 1987, but late in 1986 the Pathfinder project was told to adapt the existing design of a free-flying satellite for launch on an expendable vehicle. The launch date was expected to slip to 1990.”* [2] (JPL report 1986, NASA JPL Pasadena)

*“The Mars Global Surveyor and Mars Pathfinder spacecraft inaugurated a return to the Red Planet in 1996 with their launches atop McDonnell Douglas Delta II. rockets-two decades after the landmark Viking missions. Surveyor was launched 10-month cruise to the planet, where it will map the Martian globe in polar orbit for at least two years. Pathfinder, the first in NASA's Discovery series of low-cost, highly focused missions, was launched December 4, with the goal of placing a lander and the small (11.5-kilogram) Sojourner rover on the Martian surface on July 4, 1997.”*[3] (JPL report, NASA JPL Pasadena 1996)

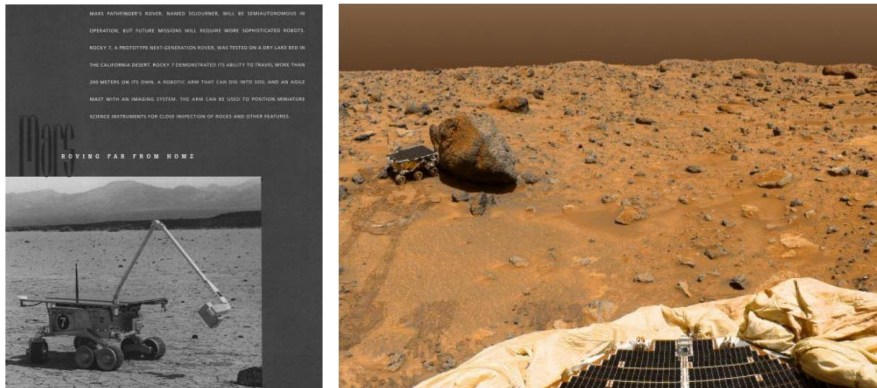

Figure 7, 8

Pathfinder: JPL report 1986, 1997, NASA JPL CA, Pasadena [2, 4]

The remote control methods of the Pathfinder were prepared and developed by JPL researchers. During the project, they needed to confirm the “remote controlled sensing”, the operation of the robot arms equipped with sensors. *“On a robotic arm there is no hand. Instead of a hand there are spectroscopic instruments (alpha particle X-ray spectrometer for determining the components of the soil), therefore, the movement of these had to be designed so that they did not collide with the material being investigated. It was only data for spectral analysis that was sent and received...”*—said professor Bejczy in 2012.

## 2 President of the IEEE Council of Robotics and Automation and IEEE Fellow



Dr. Bejczy was a frequent organizer of tutorials, workshops and sessions on robotics at the conferences for the Institution of Electrical and Electronics Engineers (IEEE). He gave lectures and seminars on robotics topics at twenty four universities in nine countries.

He was Chairman of the IEEE Control System Society Technical Committee on Robotics and Automation from 1983 to 1985, General Chairman of the IEEE International Conference on Robotics and Automation in San Francisco, California in 1986, and President of the IEEE Council of Robotics and Automation in 1987 when he helped to transform the Council of the current IEEE Robotics and Automation Society (RAS), with about seven thousand members.

He served as a member of the Governing Board of the IEEE RAS during 1989-1991, and reelected for 1994-1999. He was the General Chair of the 8. International Conference on Advanced Robotics (ICAR) in Monterey, CA in 1997 and the

General Co-Chair of the 10<sup>th</sup> ICAR in Budapest, Hungary in 2001, Program Co-Chair for the 11<sup>th</sup> ICAR in Coimbra, Portugal, in 2003.



Figure 9

IEEE RAS Past-President Dinner at his last ICRA in St. Paul (2012)

He received the IEEE Fellow honor, in 1987, for “*Contributions to the theory and applications of robotics*”, and the Jean Vertut Award of the Society of the Manufacturing Engineering & Robotics International (SME&RI) for the “*Remote application of robotic technology*,” in 1991 the NASA Exceptional Service Medal for “*Sustained contributions to innovative technology and NASA leadership in advanced teleoperation*,” in 1994 the NASA Flight Experiment Achievement Certificate for “*Outstanding contribution on the Dexterous End Effector Flight Demonstration*,” in 2000 the “*IEEE Third Millennium Medal for outstanding achievements and contributions*,” in 2004 the IEEE RAS Pioneer Award “*For seminal technical contribution to robotics and teleoperation and pioneer research in space robotics and human-robot interfaces*,” in 2007 the IEEE RAS Distinguished Service Award “*For outstanding contribution to Robotics and Automation Society professional activities and his leadership as the IEEE Robotics and Automation Society Council Chair who fostered the transition from a Council to a Society*.”

In 2007 he received the American Institute of Aeronautics and Astronautics (AIAA) Space Automation and Robotics Award “*For establishing the foundation of robotics for space applications and pioneering the development of key enabling techniques to overcome the special challenges of communication delay, operation feedback, and unstructured environment*.” That award was augmented in 2007 by the International Technology Institute’s (ITI) “*Diploma for Hall of Fame*,” together with the ITI highest award, “*The Willard F. Rockwell, Jr. Medal*.”

He was also the recipient of the 2009 IEEE Robotics and Automation “*Technical Field Award*” (TFA) “*For leadership and sustained contribution to a broad set of innovative robotic and automation techniques applicable to space research and on Earth*.”

### 3 Prof. Dr. Antal K. Bejczy: 34 NASA Innovation Awards and 7 U.S. Patents.

He received forty-three NASA innovation awards and holds seven U.S. patents. He pioneered the development of innovative robot components such as smart hands with smart sensors and a novel telerobotic system using a general-purpose force-reflecting hand controller for remote robot arm control, which contributed to the birth of haptic research[7]. The results of Antal K. Bejczy's research projects were collected in seven U.S. patents: (source: NASA Technical Reports (NTRS) [7]

#### 1. Terminal Guidance Sensor System: No. 4260187 (1979)

*“Abstract: A system is described for guiding a claw to the proper distance and into the proper orientation in yaw and pitch, to engage a grappling fixture. The system includes four proximity sensors on the claw, that are arranged at the corners of an imaginary square, which sense the distance to the top surface of the grappling fixture. If a pair of sensors at opposite corners of the square sense a different distance to the top surface of the grappling fixture, then it is known that the claw is rotated about a corresponding axis with respect to the plane of the grappling fixture.”* (Inventors: Robert A. Administrator of the National Aeronautics and Space Administration, with respect to an invention of Frosch, Antal K. Bejczy.

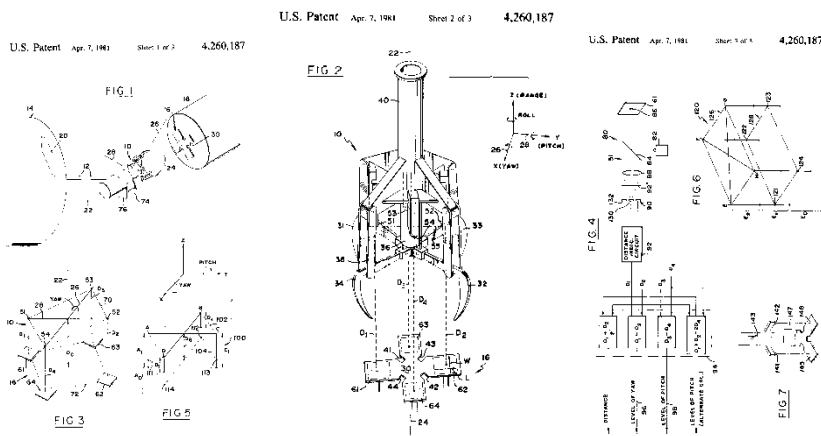

Figure 10

Terminal Guidance Sensor System: No. 4260187 (1979) US Patents

#### 2. Optical fiber tactile sensor: No. 4405197 (1983)

*“Abstract: A tactile sensor comprises an array of cells, which are covered by an elastic membrane, having an exposed surface which is adapted to come in contact with an object. Light is conducted to each cell from a light source by an optical fiber which terminates at the cell. Reflected light from the cell is conducted by an*



optical fiber to a light processor, which senses changes in the light received thereby from an ambient level whenever an object comes in contact with the membrane surface above the cell.”(Inventor: Antal K. Bejczy)

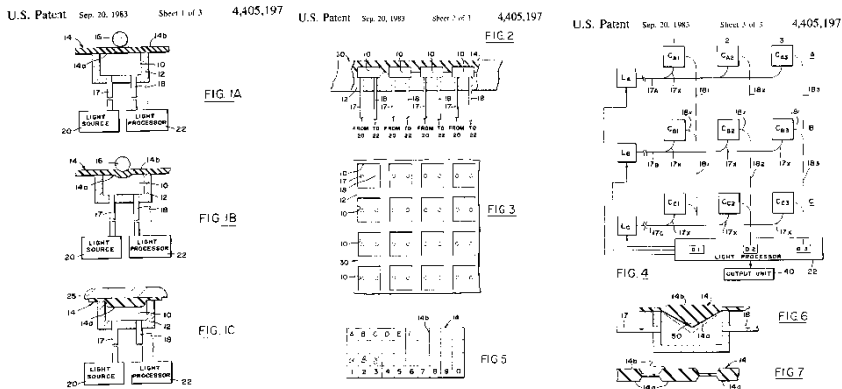

Figure 11

Optical fiber tactile sensor: No. 4405197 (1983) US Patents

### 3. Linear Array Optical Edge Sensor: No. 4694153 (1987)

“Abstract: A series of independent parallel pairs of light emitting and detecting diodes for a linear pixel array, which is laterally positioned over an edge-like discontinuity in a work piece to be scanned, is disclosed. These independent pairs of light emitters and detectors sense along intersecting pairs of separate optical axes. A discontinuity, such as an edge of the sensed work piece, reflects a detectable difference in the amount of light from that discontinuity in comparison to the amount of light that is reflected on either side of the discontinuity. A sequentially synchronized clamping and sampling circuit detects that difference as an electrical signal which is recovered by circuitry that exhibits an improved signal-to-noise capability for the system.” (Inventors: Antal K. Bejczy, Howard C. Primus)

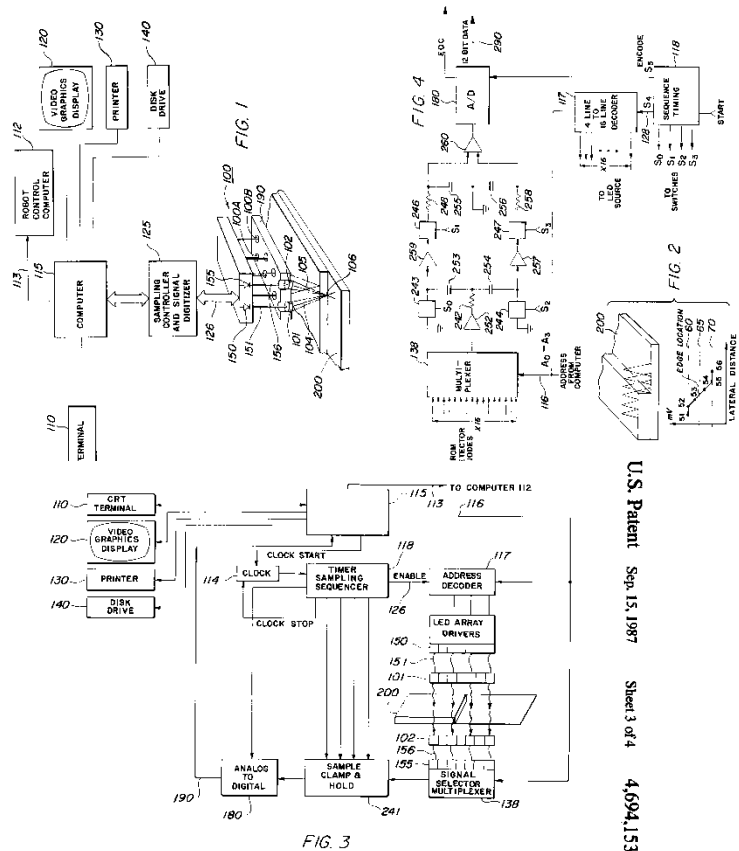

Figure 12

Linear Array Optical Edge Sensor: No. 4694153 (1987) US Patents

4. Grasp Force Sensor for Robotic Hands: No. 4819978 (1989)

“Abstract: A grasp force sensor for robotic hands is disclosed. A flexible block is located in the base of each claw through which the grasp force is exerted. The block yields minute parallelogram deflection when the claws are subjected to grasping forces. A parallelogram deflection closely resembles pure translational deflection, whereby the claws remain in substantial alignment with each other during grasping. Strain gauge transducer supply signals which provide precise knowledge of and control over grasp forces.”(Inventors: Victor D. Scheinman, Antal K. Bejczy, Howard C. Primus)

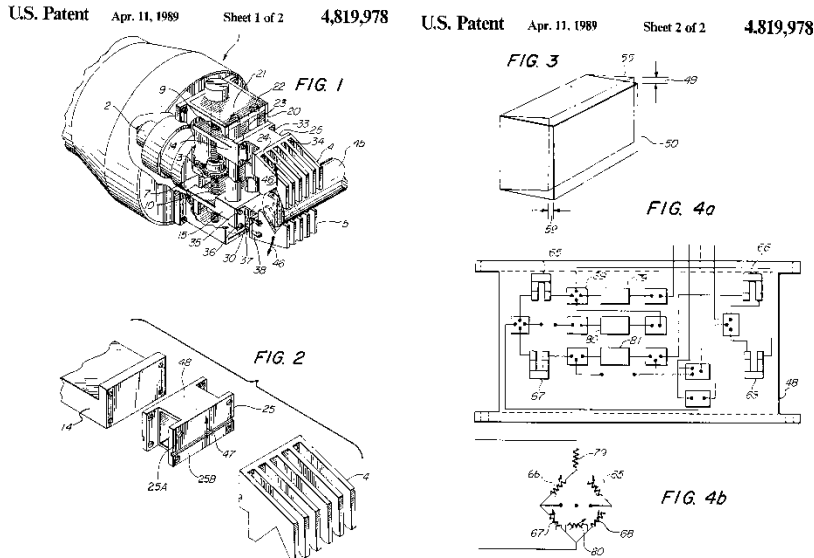

Figure 13

Grasp Force Sensor for Robotic Hands: No. 4819978 (1989) U.S. Patents

The research of Antal Bejczy was focused around a basic concept, that “without the elaboration of the robot–human interaction there is no such thing as successful robotics”. By Amir Fijany, Sherman Oaks and Antal Bejczy [8] created two patents based on the results of the experiments:

##### 5. Special purpose parallel computer architecture for real-time control and simulation in robotic applications: No 5218709 (1993)

“Abstract: A Real-time Robotic Controller and Simulator (RRCS) with an MIMD-SIMD parallel architecture for interfacing with an external host computer provides a high degree of parallelism in computation for robotic control and simulation. A host processor receives instructions from, and transmits answers to, the external host computer. A plurality of SIMD microprocessors, each SIMD processor being an SIMD parallel processor, is capable of exploiting fine-grain parallelism and is able to operate asynchronously to form an MIMD architecture. Each SIMD processor comprises an SIMD architecture capable of performing two matrix-vector operations in parallel while fully exploiting parallelism in each operation. A system bus connects the host processor to the plurality of SIMD microprocessors and a common clock provides a continuous sequence of clock pulses.” (Inventors: Amir Fijany, Antal K. Bejczy.)

U.S. Patent June 8, 1993 Sheet 1 of 2 5,218,709 U.S. Patent June 8, 1993 Sheet 2 of 2 5,218,709

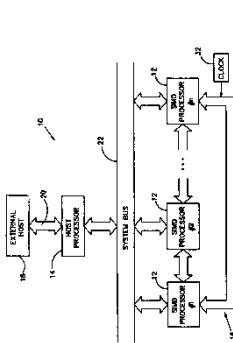

FIG. 1

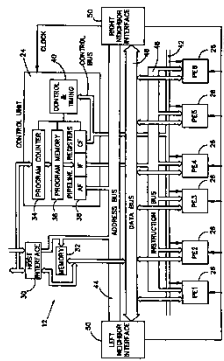

FIG. 2

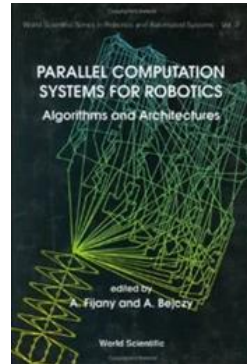

Figure 14, 15

14: Special purpose parallel computer architecture for real-time control and simulation in robotic applications: No 5218709 (1993) US Patents

15: Parallel Computation Systems for Robotics Algorithms and Architectures Edited by: A Fijany (JPL/Caltech), A Bejczy (JPL/Caltech) ISBN: 978-981-02-0663-5 [8]

In 1993, NASA scientists at JPL, were using a new remote control technology and during the test, a new graphically oriented program, to remotely control a robot arm at the NASA' Goddard Space Flight Center. The experiment's technical manager was Dr. Bejczy at JPL. The technology was licensed by a private firm and the main target of the free-flying robots was the service of the existing orbiting satellites, for many possible uses on Earth, like the clean-up of toxic or nuclear waste sites or for special medical procedures. The main target of the robotic arm was to insert a screwdriver into an 18 inch deep hole, to reach the latching mechanism while in Space, but the operator controlled the robotic arm from Earth. A special software, that allows the remote operator to superimpose high-fidelity computer graphics models of the robot arm and satellite module, on the monitor in live-scene and make visible, but hidden critical motion events.

“The operator is able to generate, predict or preview motions without commanding the actual hardware and can see the consequences in real time”-said Professor Bejczy in 1993. One of the most important projects of Professor Bejczy, was to find a solution for time delays and to use the robotic arm in real time.

6. Highly parallel reconfigurable computer architecture for robotic computation having plural processor cells, each having right and left ensembles of plural processors: No:5361367 (1994)

“Abstract: In a computer having a large number of single-instruction multiple data (SIMD) processors, each of the SIMD processors has two sets of three individual processor elements controlled by a master control unit and interconnected among a plurality of register file units where data is stored. The register files input and output data in synchronism with a minor cycle clock under the control of two slave control units controlling the register file units connected to respective ones of the two sets of processor elements. Depending upon which ones of the register file units are enabled to store or transmit data during a particular minor clock cycle, the processor elements within an SIMD processor are connected with rings or in pipeline arrays, and may exchange data with the internal bus or with neighboring SIMD processors through interface units controlled by respective ones of the two slave control units. (Inventors: Amir Fijany, Antal K. Bejczy.)

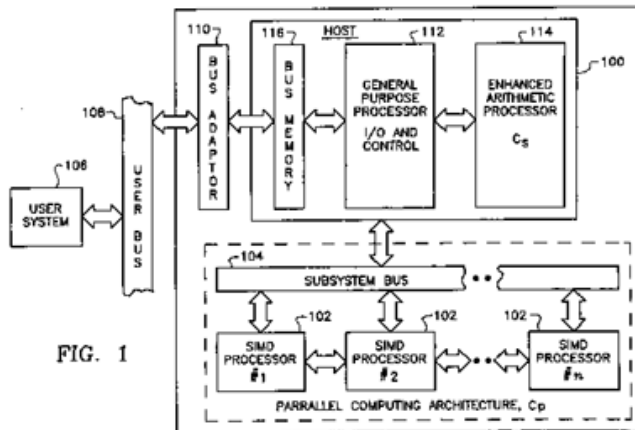

FIG. 1

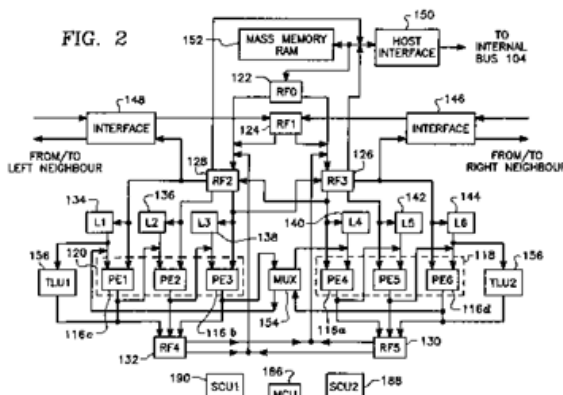

FIG. 2

U.S. Patent No. 5,361,367 Nov. 1, 1994 Sheet 1 of 4

U.S. Patent No. 5,361,367 Nov. 1, 1994 Sheet 2 of 4

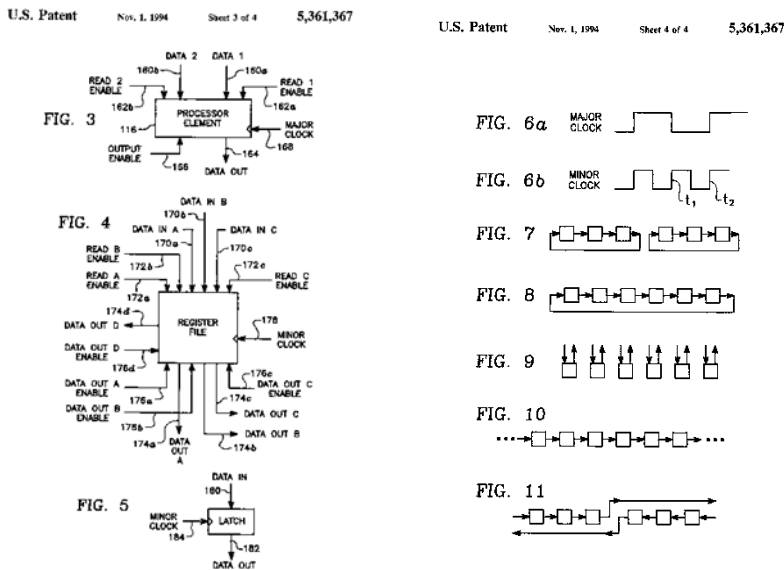

Figure 12

Highly parallel reconfigurable computer architecture for robotic computation having plural processor cells, each having right and left ensembles of plural processors: No:5361367 (1994) US Patents

Many new technologies for space exploration were later, very important and significant applications within the field of human medical applications. Antal Bejczy, the senior research scientist and lead engineer was also working on several projects at JPL like the robotic stepper device. The scientists were working together with therapists to support the rehabilitation of patients with lower stepping capacity, for example, after a stroke, neuromotor disorders or spinal injuries. The highly sensitive sensors were able to collect twenty four different data about the patients movement on the computer screen. Also an important result of this method that his system had been replaced the work of four therapists.

### 7. Method, apparatus and system for automation of body weight support training (BWST) of biped locomotion over a treadmill using a programmable stepper device (PSD) operating like an exoskeleton drive system from a fixed base. No: 6666831 (2003)

*“Abstract: A robotic exoskeleton and a control system for driving the robotic exoskeleton, including a method for making and using the robotic exoskeleton and its control system. The robotic exoskeleton has sensors embedded in it which provide feedback to the control system. Feedback is used to the motion of the legs themselves, as they deviate from a normal gait, to provide corrective pressure and guidance. The position versus time is sensed and compared to a normal gait profile. Various normal profiles are obtained based on studies of the population for age, weight, height and other variables”.*(Inventors: V. Reggie Edgerton, M. Kathleen Day, Susan Harkema, Antal K. Bejczy, James R. Weiss)

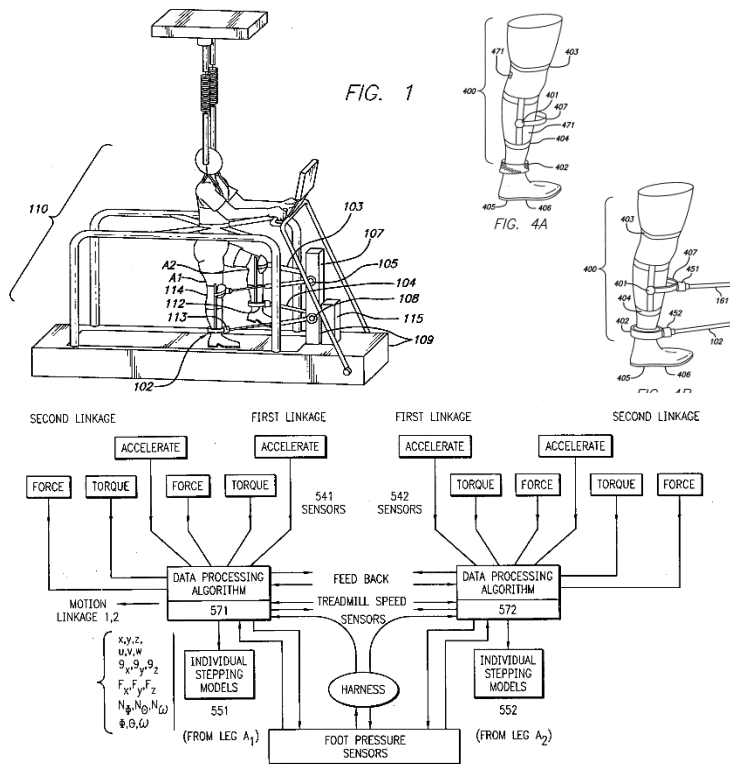

FIG. 5

Figure 12

Method, apparatus and system for automation of body weight support training (BWST) of biped locomotion over a treadmill using a programmable stepper device (PSD) operating like an exoskeleton drive system from a fixed base. No: 6666831 (2003) US Patents

Already in 1980 was published by Antal K. Bejczy and J. K. Salisbury the basic mechanism of the force reflecting hand controller where the band controller able to measure three positions (x, y, z) and also three orientations like the pitch, yaw and roll. Because of the forces and torques in three positional and three rotational axes of the hand controller, the operator able to feel the task he is controlling. Bejczy at al 1980 [12]

### 3.1 Anthropomorphic Telemanipulation System

The theory described the prototype anthropomorphic kinesthetic Telepresence system. Antal K. Bejczy and his colleagues at the JPL laboratory (B. M. Jau and M. A. Lewis ) presented the results in the book titled: Theory and Practice of Robots and Manipulators. "The newly developed master-glove is integrated with

our previously developed non-anthropomorphic six degree-of-freedom universal force reflecting hand controller. The system is controlled by high performance distributed controller. Control electronics and computing architecture were custom developed for this telemanipulation system. The system is currently being evaluated, focusing on tool handling and astronaut equivalent task executions. The evaluation revealed the system's potential for tool handling but it also became evident that hand tool manipulations and space operations require a dual arm robot. " [9]

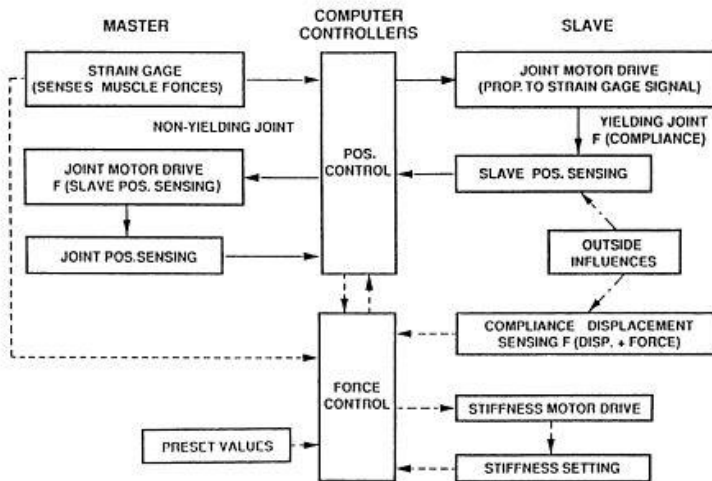

Figure 13

Anthropomorphic Telemanipulation System in Terminus Control Mode [9]

## Conclusions

During his life and career, Prof. Dr. Antal K. Bejczy was open to a wide-range of knowledge and science, from Theoretical Mathematics to Practical Physics. Wherever he worked, he received many jobs and always performed in an excellent manor. Mainly, his innovative thinking and personality, raised him to be among the best scientists.

The oeuvre of Prof. Dr. Antal K. Bejczy (1930-2015) is a prime example for all Researchers in Hungary and Overseas. The Antal Bejczy Center for Intelligent Robotics, opened by the Óbuda University, in 2013 in Budapest. The Antal Bejczy Award (2015) and the Antal Bejczy Museum was also established by Obuda University, Hungary - University Research and Innovation Center. The Opening Ceremony will be held on the 18<sup>th</sup> of January, in 2016.

## Acknowledgement

This work was supported by Óbuda University, University Research and Innovation Center, Antal Bejczy Center for Intelligent Robotics





Figure 14

Prof. Dr. Antal K. Bejczy, honorary doctor of Óbuda University (2012)

## References

- [1] A. K. Bejczy Robot Arm Dynamics and Control (1974) NASA JPL Technical Memorandum 33-669
- [2] NASA JPL 1986 Annual Report, California Institute of Technology Pasadena, California
- [3] NASA JPL 1996 Annual Report, California Institute of Technology Pasadena, California
- [4] NASA JPL 1997 Annual Report, California Institute of Technology Pasadena, California
- [5] Parallel Computation Systems for Robotics Algorithms and Architectures Edited by: A. Fijany (JPL/Caltech), A. Bejczy (JPL/Caltech) ISBN: 978-981-02-0663-5
- [6] T. Haidegger, The Rich Heritage of Antal Bejczy, in the proceedings of INES 2015 • IEEE 19<sup>th</sup> International Conference on Intelligent Engineering Systems • September 3-5, 2015, Bratislava, Slovakia, Plenary talk
- [7] NASA Technical Reports (NTRS) Antal K. Bejczy, US Patents
- [8] Parallel Computation Systems for Robotics Algorithms and Architectures Edited by: A. Fijany (JPL/Caltech), A. Bejczy (JPL/Caltech) ISBN: 978-981-02-0663-5
- [9] B. M. Jau, M. A. Lewis, A. K. Bejczy, Theory and Practice of Robots and Manipulators, Volume 361 of the series International Centre for Mechanical Sciences, pp. 101-111, Anthropomorphic Telem Manipulation System in Terminus Control Model, ISBN 978-3-7091-2698-1 (1995)
- [10] The IEEE Robotics and Automation Society History, IEEE Robotics and Automation Award: about Antal K. Bejczy
- [11] Lewis, R. A., Bejczy A. K., RRP Manipulator Conventions, Coordinate Systems, and Trajectory Consideration. JPL Technical Memo 343-174, 1972

- [12] Bejczy, A. K. and Salisbury, J. K., Jr., "Kinesthetic Coupling Between Operator and Remote Manipulator," Proc. of ASME Int'l Computer Technology Conference, Vol. 1, San Francisco, CA, August 12-15, 1980, pp. 197-211